



# FUZE WASH Z350

User Manual

©2022 ELATION PROFESSIONAL all rights reserved. Information, specifications, diagrams, images, and instructions herein are subject to change without notice. ELATION PROFESSIONAL logo and identifying product names and numbers herein are trademarks of ELATION PROFESSIONAL. Copyright protection claimed includes all forms and matters of copyrightable materials and information now allowed by statutory or judicial law or hereinafter granted. Product names used in this document may be trademarks or registered trademarks of their respective companies and are hereby acknowledged. All non-ELATION brands and product names are trademarks or registered trademarks of their respective companies.

**ELATION PROFESSIONAL** and all affiliated companies hereby disclaim any and all liabilities for property, equipment, building, and electrical damages, injuries to any persons, and direct or indirect economic loss associated with the use or reliance of any information contained within this document, and/or as a result of the improper, unsafe, insufficient and negligent assembly, installation, rigging, and operation of this product.

**Elation Professional USA** | 6122 S. Eastern Ave. | Los Angeles, CA. 90040  
323-582-3322 | 323-832-9142 fax | [www.elationlighting.com](http://www.elationlighting.com) | [info@elationlighting.com](mailto:info@elationlighting.com)

**Elation Professional B.V.** | Junostraat 2 | 6468 EW Kerkrade, The Netherlands  
+31 45 546 85 66 | +31 45 546 85 96 fax | [www.elationlighting.eu](http://www.elationlighting.eu) | [info@elationlighting.eu](mailto:info@elationlighting.eu)

**Elation Professional Mexico**  
AV Santa Ana 30 | Parque Industrial Lerma, Lerma, Mexico 52000  
+52 (728) 282-7070

## DOCUMENT VERSION



Due to additional product features and/or enhancements, an updated version of this document may be available online. Please check [www.elationlighting.com](http://www.elationlighting.com) for the latest revision/update of this manual before beginning installation and/or programming.

| Date       | Document Version | Software Version | DMX Channels    | Notes  |
|------------|------------------|------------------|-----------------|--|
| 09/15/2016 | 1.0              | 1.0.1            | 15/16/17/19 ch. | Initial Release  |
| 09/19/2016 | 1.2              | N/C              | No Change       | Added missing section of DMX traits.   |
| 04/19/2017 | 1.3              | N/C              | No Change       | Updated zoom beam angles, max power specs  |
| 09/27/2018 | 1.4              | 1.15   2.16      | No Change       | Updated System Menu and DMX Traits; added selectable LED refresh rates   |
| 03/25/2019 | 1.6              | 2.18             | No Change       | Updated System Menu (gamma and calibrate)  |
| 07/01/2020 | 1.8              | 2.1.10           | No Change       | Updated System Menu (removed gamma, added dimmer curve settings), updated thermal  |
| 08/20/2020 | 2.0              | 2.2.11           | No Change       | Updated primary/secondary  |
| 11/10/2022 | 2.1              | N/C              | No Change       | Added Fixture Transportation, RDM, Fan Control; updated General Info, Overview, Installation Guidelines, System Menu, Specifications |

## TABLE OF CONTENTS

|                                      |    |
|--------------------------------------|----|
| General Information                  | 4  |
| Limited Warranty (USA Only)          | 5  |
| Safety Precautions                   | 6  |
| Fixture Transportation               | 8  |
| Maintenance Guidelines               | 9  |
| Overview                             | 10 |
| Installation Guidelines              | 11 |
| Accessory Installation               | 15 |
| Remote Device Management (RDM)       | 16 |
| System Menu                          | 17 |
| Fan Control                          | 23 |
| DMX Traits                           | 24 |
| Error Codes                          | 28 |
| Specifications                       | 29 |
| Dimensional Drawings                 | 30 |
| Optional Accessories   FCC Statement | 32 |

# GENERAL INFORMATION

## INTRODUCTION

Please read and understand the instructions in this manual carefully and thoroughly before attempting to operate this device. These instructions contain important safety and use information. **This device is intended for use by trained personnel only, and is not suitable for private use.**

## UNPACKING

Every device has been thoroughly tested and has been shipped in perfect operating condition. Carefully check the shipping carton for damage that may have occurred during shipping. If the carton is damaged, carefully inspect the device for damage, and be sure all accessories necessary to install and operate the device have arrived intact. In the event that damage has been found or parts are missing, please contact our customer support team for further instructions. Please do not return this device to your dealer without first contacting customer support. Please do not discard the shipping carton in the trash. Please recycle whenever possible.

## BOX CONTENTS

Power Cable (x1)  
Omega Brackets (x2)

## CUSTOMER SUPPORT

Contact ELATION Service for any product related service and support needs. Also visit [forums.elationlighting.com](https://forums.elationlighting.com) with questions, comments or suggestions.

**ELATION SERVICE USA** - Monday - Friday 8:00am to 4:30pm PST  
323-582-3322 | Fax 323-832-9142 | [support@elationlighting.com](mailto:support@elationlighting.com)

**ELATION SERVICE EUROPE** - Monday - Friday 08:30 to 17:00 CET  
+31 45 546 85 63 | Fax +31 45 546 85 96 | [support@elationlighting.eu](mailto:support@elationlighting.eu)

**REPLACEMENT PARTS** - please visit [parts.elationlighting.com](https://parts.elationlighting.com)

**THERE ARE NO USER SERVICEABLE PARTS INSIDE THIS UNIT. DO NOT ATTEMPT ANY REPAIRS YOURSELF, AS DOING SO WILL VOID YOUR MANUFACTURER'S WARRANTY. DAMAGES RESULTING FROM MODIFICATIONS TO THIS FIXTURE AND/OR THE DISREGARD OF SAFETY INSTRUCTIONS AND GUIDELINES IN THIS MANUAL VOID THE MANUFACTURER'S WARRANTY AND ARE NOT SUBJECT TO ANY WARRANTY CLAIMS AND/OR REPAIRS.**

## LIMITED WARRANTY (USA ONLY)

- A. Elation Professional hereby warrants, to the original purchaser, Elation Professional products to be free of manufacturing defects in material and workmanship for a period of two years (730 days), and Elation Professional product rechargeable batteries to be free of manufacturing defects in material and workmanship for a period of six months (180 days), from the original date of purchase. This warranty excludes discharge lamps and all product accessories. This warranty shall be valid only if the product is purchased within the United States of America, including possessions and territories. It is the owner's responsibility to establish the date and place of purchase by acceptable evidence, at the time service is sought.
- B. For warranty service, send the product only to the Elation Professional factory. All shipping charges must be pre-paid. If the requested repairs or service (including parts replacement) are within the terms of this warranty, Elation Professional will pay return shipping charges only to a designated point within the United States. If any product is sent, it must be shipped in its original package and packaging material. No accessories should be shipped with the product. If any accessories are shipped with the product, Elation Professional shall have no liability what so ever for loss and/or or damage to any such accessories, nor for the safe return thereof.
- C. This warranty is void if the product serial number and/or labels are altered or removed; if the product is modified in any manner which Elation Professional concludes, after inspection, affects the reliability of the product; if the product has been repaired or serviced by anyone other than the Elation Professional factory unless prior written authorization was issued to purchaser by Elation Professional; if the product is damaged because not properly maintained as set forth in the product instructions, guidelines and/or user manual.
- D. This is not a service contract, and this warranty does not include any maintenance, cleaning or periodic check-up. During the periods as specified above, Elation Professional will replace defective parts at its expense, and will absorb all expenses for warranty service and repair labor by reason of defects in material or workmanship. The sole responsibility of Elation Professional under this warranty shall be limited to the repair of the product, or replacement thereof, including parts, at the sole discretion of Elation Professional. All products covered by this warranty were manufactured after January 1, 1990, and bare identifying marks to that effect.
- E. Elation Professional reserves the right to make changes in design and/or performance improvements upon its products without any obligation to include these changes in any products theretofore manufactured.
- F. No warranty, whether expressed or implied, is given or made with respect to any accessory supplied with the products described above. Except to the extent prohibited by applicable law, all implied warranties made by Elation Professional in connection with this product, including warranties of merchantability or fitness, are limited in duration to the warranty periods set forth above. And no warranties, whether expressed or implied, including warranties of merchantability or fitness, shall apply to this product after said periods have expired. The consumer's and/or dealer's sole remedy shall be such repair or replacement as is expressly provided above; and under no circumstances shall Elation Professional be liable for any loss and/or damage, direct and/or consequential, arising out of the use of, and/or the inability to use, this product.
- G. This warranty is the only written warranty applicable to Elation Professional products and supersedes all prior warranties and written descriptions of warranty terms and conditions heretofore published.

### WARRANTY RETURNS

All returned service items whether under warranty or not, must be freight pre-paid and accompanied by a return authorization (R.A.) number. The R.A. number must be clearly written on the outside of the return package. A brief description of the problem, as well as the R.A. number, must also be written down on a piece of paper and included in the shipping container. If the unit is under warranty, you must provide a copy of your proof of purchase invoice. Items returned without an R.A. number clearly marked on the out-side of the package will be refused and returned at customer's expense. You may obtain an R.A. number by contacting customer support.

## **SAFETY GUIDELINES**

This fixture is a sophisticated piece of electronic equipment. To guarantee a smooth operation, it is important to follow all instructions and guidelines in this manual. Elation Professional is not responsible for injuries and/or damages resulting from the misuse of this fixture due to the disregard of the information printed in this manual. Only qualified and/or certified personnel should perform installation of this fixture and only the original rigging parts included with this fixture should be used for installation. Any modifications to the fixture and/or the included mounting hardware will void the original manufacturer's warranty and increase the risk of damage and/or personal injury



**PROTECTION CLASS 1 - FIXTURE MUST BE PROPERLY GROUNDED.**



**THERE ARE NO USER SERVICEABLE PARTS INSIDE THIS UNIT. DO NOT ATTEMPT ANY REPAIRS YOURSELF, AS DOING SO WILL VOID YOUR MANUFACTURER'S WARRANTY. DAMAGES RESULTING FROM MODIFICATIONS TO THIS FIXTURE AND/OR THE DISREGARD OF SAFETY INSTRUCTIONS AND GUIDELINES IN THIS MANUAL VOID THE MANUFACTURER'S WARRANTY AND ARE NOT SUBJECT TO ANY WARRANTY CLAIMS AND/OR REPAIRS.**



**DO NOT PLUG FIXTURE INTO A DIMMER PACK!  
NEVER OPEN THIS FIXTURE WHILE IN USE!  
UNPLUG POWER BEFORE SERVICING FIXTURE!  
NEVER TOUCH FIXTURE DURING OPERATION, AS IT MAY BE HOT! KEEP FLAMMABLE MATERIALS AWAY FROM FIXTURE!**



**DO NOT PLUG FIXTURE INTO A DIMMER PACK!  
NEVER OPEN FIXTURE WHILE IN USE!  
UNPLUG POWER BEFORE SERVICING!  
NEVER TOUCH FIXTURE DURING OPERATION, AS SURFACES MAY BE HOT!  
KEEP FLAMMABLE MATERIALS WELL AWAY FROM FIXTURE!**



**NEVER LOOK DIRECTLY INTO THE LIGHT SOURCE!  
RETINA INJURY RISK - MAY INDUCE BLINDNESS!  
SENSITIVE PERSONS MAY SUFFER AN EPILEPTIC SHOCK!**



**INDOOR / DRY LOCATIONS ONLY!  
DO NOT EXPOSE TO RAIN AND / OR MOISTURE!**

## **SAFETY GUIDELINES**

- DO NOT TOUCH the fixture housing during operation. Turn OFF the power and allow approximately 15 minutes for the fixture to cool down before servicing.
- DO NOT shake fixture, and avoid brute force when installing and/or operating fixture.
- DO NOT operate fixture if the power cord is frayed, crimped, damaged, and/or if any of the power cord connectors are damaged and do not insert into the fixture securely with ease. NEVER force a power cord connector into the fixture. If the power cord or any of its connectors are damaged, replace it immediately with a new one of the same power rating.
- DO NOT block any air ventilation slots. All fan and air inlets must remain clean and never blocked.
- Allow approx. 6" (15cm) between fixture and other devices or a wall for proper cooling.
- When installing fixture in a suspended environment, always use mounting hardware that is no less than M10 x 25 mm, and always install fixture with an appropriately rated safety cable.
- Always disconnect fixture from main power source before performing any type of service and/or cleaning procedure.
- Only handle the power cord by the plug end. Never pull out the plug by tugging the wire portion of the cord.
- During the initial operation of this fixture, a light smoke or smell may emit from the interior of the fixture. This is a normal process and is caused by excess paint in the interior of the casing burning off from the heat associated with the lamp and will decrease gradually over time.
- Consistent operational breaks will ensure fixture will function properly for many years.

## FIXTURE TRANSPORTATION

The device is a large format fixture that contains delicate optics and glass filters. While this product was carefully designed to be roadworthy, it must be handled carefully during transportation. If your fixture features color flags, ensure before transport that the color flags are placed in an OPEN position. For superior impact protection, the fixture should be shipped in a custom fitted high-density Foam Inlay (FIL). This FIL must be used inside the road-cases for transportation.

**DO NOT** tip the case over, and avoid all shocks and rough handling, especially “tipping”, the practice of tipping the fixture-case over to its side and onto a hard surface. The case must ride on its wheels so that the fixture-head remains horizontal during transportation.

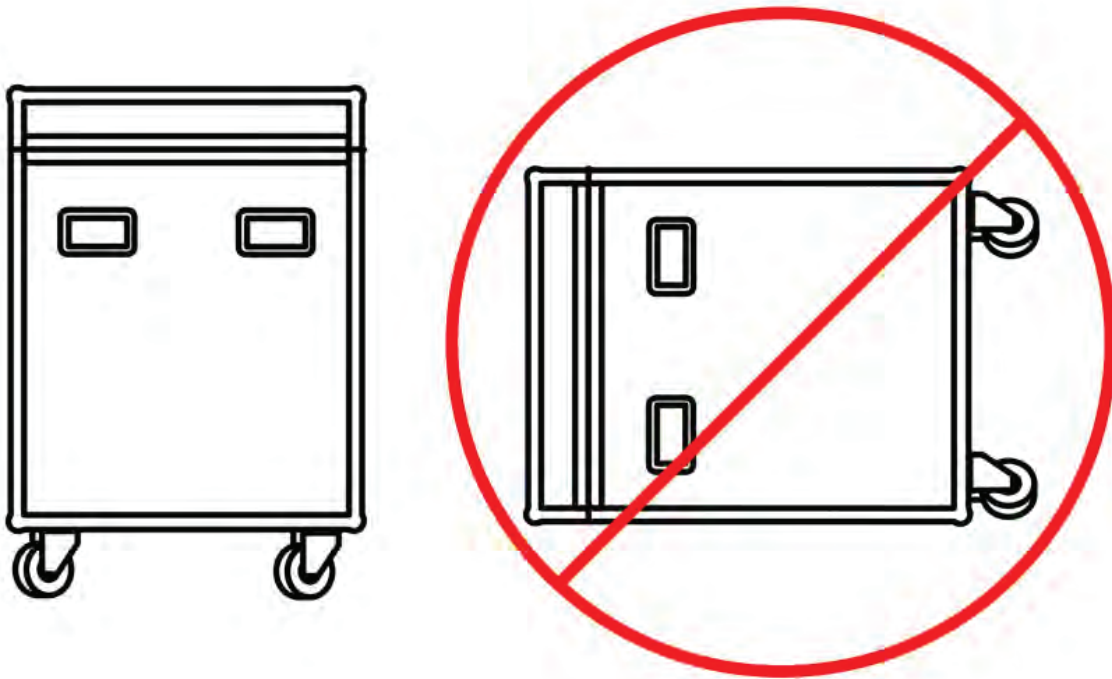



## MAINTENANCE GUIDELINES



**DISCONNECT POWER BEFORE PERFORMING ANY MAINTENANCE!**

### CLEANING

Frequent cleaning is recommended to ensure proper function, optimized light output, and an extended life. The frequency of cleaning depends on the environment in which the fixture operates: damp, smoky or particularly dirty environments can cause greater accumulation of dirt on the fixture's optics. Periodically clean the external lens surface with a soft cloth to avoid dirt/debris accumulation. **NEVER** use alcohol, solvents, or ammonia-based cleaners.

### MAINTENANCE

Regular inspections are recommended to insure proper function and extended life. There are no user serviceable parts inside this fixture. Please refer all other service issues to an authorized Elation service technician. Should you need any spare parts, please order genuine parts from your local Elation dealer.

Please refer to the following points during routine inspections:

- A detailed electrical check by an approved electrical engineer every three months, to make sure the circuit contacts are in good condition and prevent overheating.
- Be sure all screws and fasteners are securely tightened at all times. Loose screws may fall out during normal operation, resulting in damage or injury as larger parts could fall.
- Check for any deformations on the housing, color lenses, rigging hardware, and rigging points (ceiling, suspension, trussing). Deformations in the housing could allow for dust to enter into the fixture. Damaged rigging points or unsecured rigging could cause the fixture to fall and seriously injure a person(s).
- Electrical power supply cables must not show any damage, material fatigue, or sediments.

**NEVER** remove the ground prong from the power cable.

# OVERVIEW

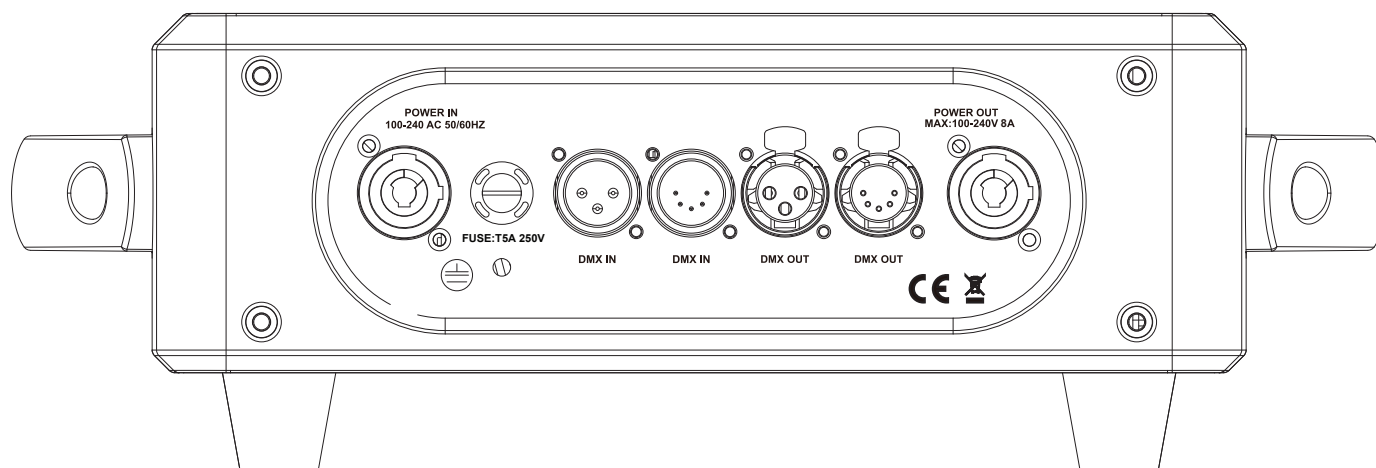
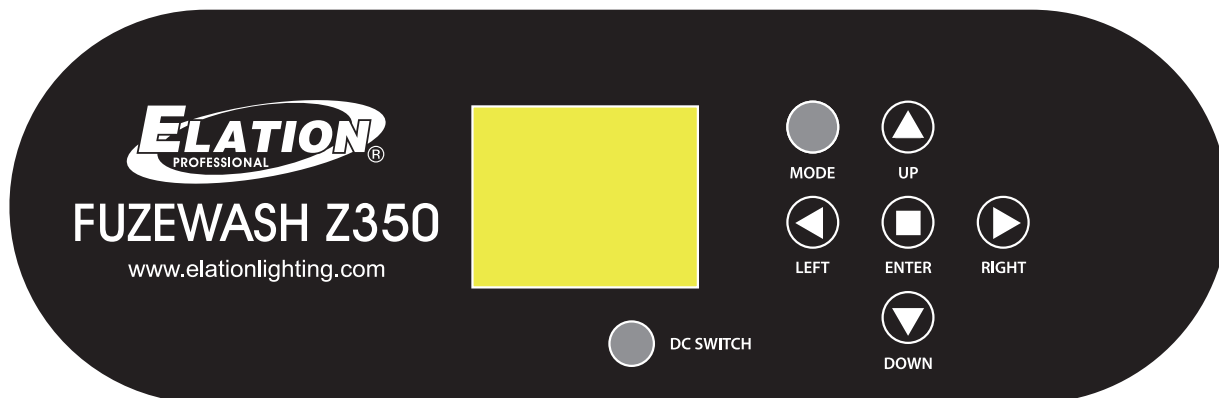

## INSTALLATION GUIDELINES



### FLAMMABLE MATERIAL WARNING

Keep fixture minimum 5.0 feet (1.5m) away from flammable materials and/or pyrotechnics.



### ELECTRICAL CONNECTIONS

A qualified electrician should be used for all electrical connections and/or installations.



**MINIMUM DISTANCE TO SURFACES/OBJECTS IS 3.3 FEET (1 METER).**

**MINIMUM DISTANCE TO FLAMMABLE MATERIALS IS 1.6 FEET (0.5 METER).**



**DO NOT INSTALL THE FIXTURE IF YOU ARE NOT QUALIFIED TO DO SO!**

Fixture **MUST** be installed following all local, national, and country commercial electrical and construction codes and regulations.

Before rigging/mounting a single fixture or multiple fixtures to any metal truss/structure or placing the fixture(s) on any surface, a professional equipment installer **MUST** be consulted to determine if the metal truss/structure or surface is properly certified to safely hold the combined weight of the fixture(s), clamps, cables, and accessories.

Overhead rigging requires extensive experience, including calculating working load limits, installation material being used, and periodic safety inspection of all installation material and the fixture, among other skills. If you lack these qualifications, do not attempt the installation yourself. Improper installation can result in bodily injury.

Fixture ambient operating temperature is **14°F to 113°F (-10°C to 45°C)**. Do not operate the fixture when the ambient temperature falls outside of this range.

Do not install outdoors or expose to rain and/or moisture. Fixture is intended for use in dry, indoor areas only.

Fixture(s) should be installed away from walking paths, seating areas, or areas where unauthorized personnel might reach the fixture by hand.

**NEVER** stand directly below the fixture(s) when rigging, removing, or servicing.

Overhead fixture installation must always be secured with a secondary safety attachment, such as an appropriately rated safety cable.

Allow approximately 15 minutes for the fixture to cool down before servicing.

# INSTALLATION GUIDELINES

## OMEGA BRACKET INSTALLATION

Insert the Omega Brackets into the matching holes on the bottom of the fixture. Secure the Omega Brackets to the fixture by turning each quick-lock fastener ¼ turn clockwise, and make sure each fastener is completely locked. Install brackets as illustrated below.

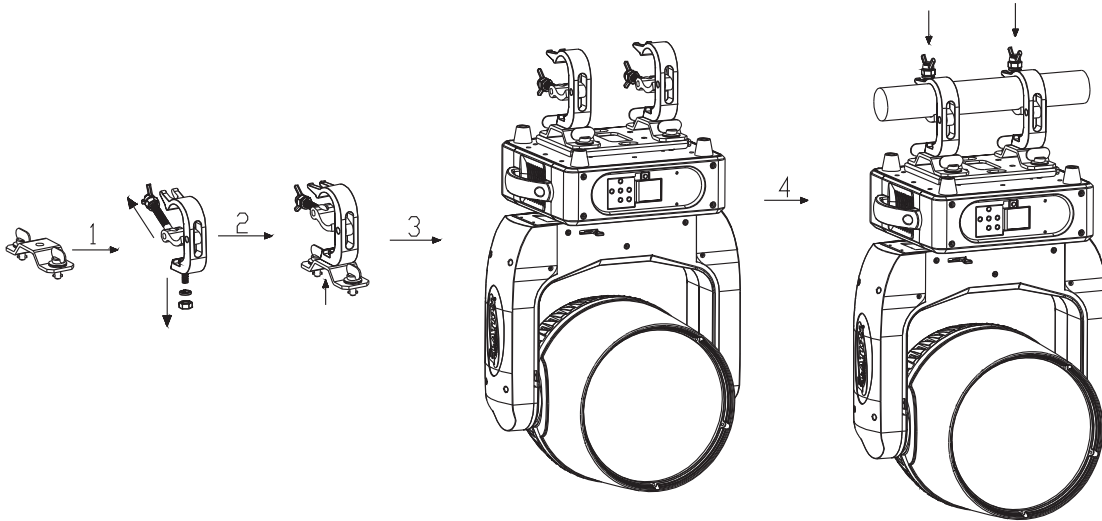

## CLAMP INSTALLATION

When mounting fixture to truss, secure an appropriately rated professional grade rigging clamp to the included Omega Brackets or Single Clamp Bracket Kit. Insert an M10 screw through the center hole of the Omega Brackets or through the center hole of the Single Clamp Bracket Kit. The fixture provides a built-in rigging point for a SAFETY CABLE. Be sure to only use the designated rigging point for the safety cable and never secure a safety cable to a carrying handle.



**ALWAYS ATTACH A SAFETY CABLE WHENEVER INSTALLING THIS FIXTURE IN A SUSPENDED ENVIRONMENT TO ENSURE THAT THE FIXTURE WILL NOT FALL IF THE CLAMP FAILS. ONLY USE DESIGNATED RIGGING POINTS FOR SAFETY CABLE, AND NEVER ATTACH A SAFELY CABLE TO A CARRYING HANDLE.**

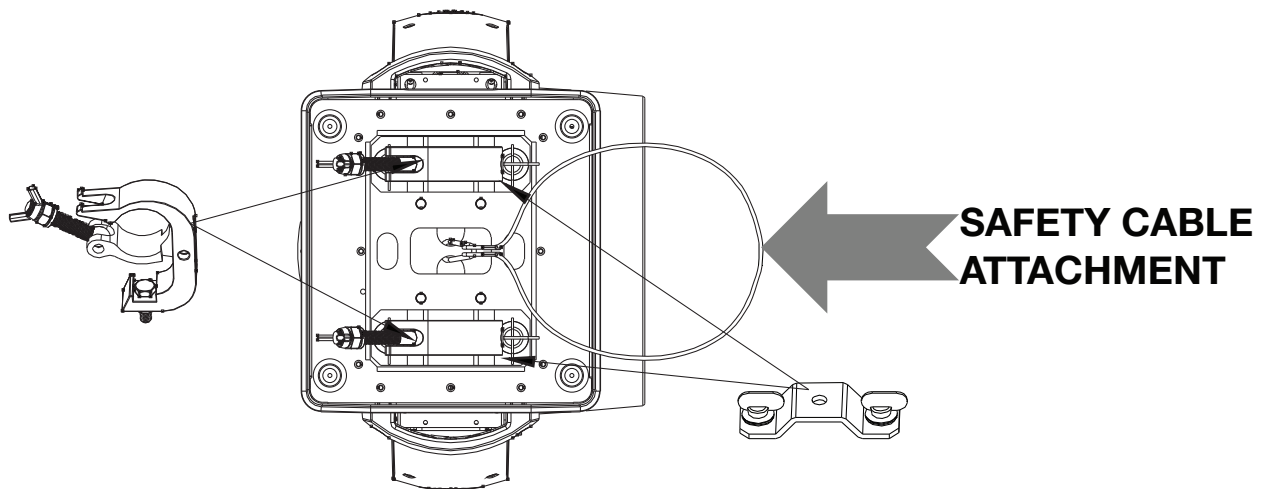

# INSTALLATION INSTRUCTIONS

## POWER LINKING:

USE CAUTION WHEN POWER LINKING OTHER FIXTURES OF OTHER MAKES OR MODEL TYPES, AS THE POWER CONSUMPTION OF OTHER MODEL FIXTURES MAY EXCEED THE MAX POWER OUTPUT ON THIS FIXTURE. CHECK SILK SCREEN FOR MAX AMPS.

## RIGGING

Overhead rigging requires extensive experience, including calculating working load limits, installation material being used, and periodic safety inspection of all installation material and the fixture, among other skills. If you lack these qualifications, do not attempt the installation yourself. Improper installation can result in bodily injury.

The fixture is fully operational in the following positions: hanging from a horizontal truss, suspended sideways from a vertical truss, or standing upright on a flat, level surface. See the illustration below for reference.

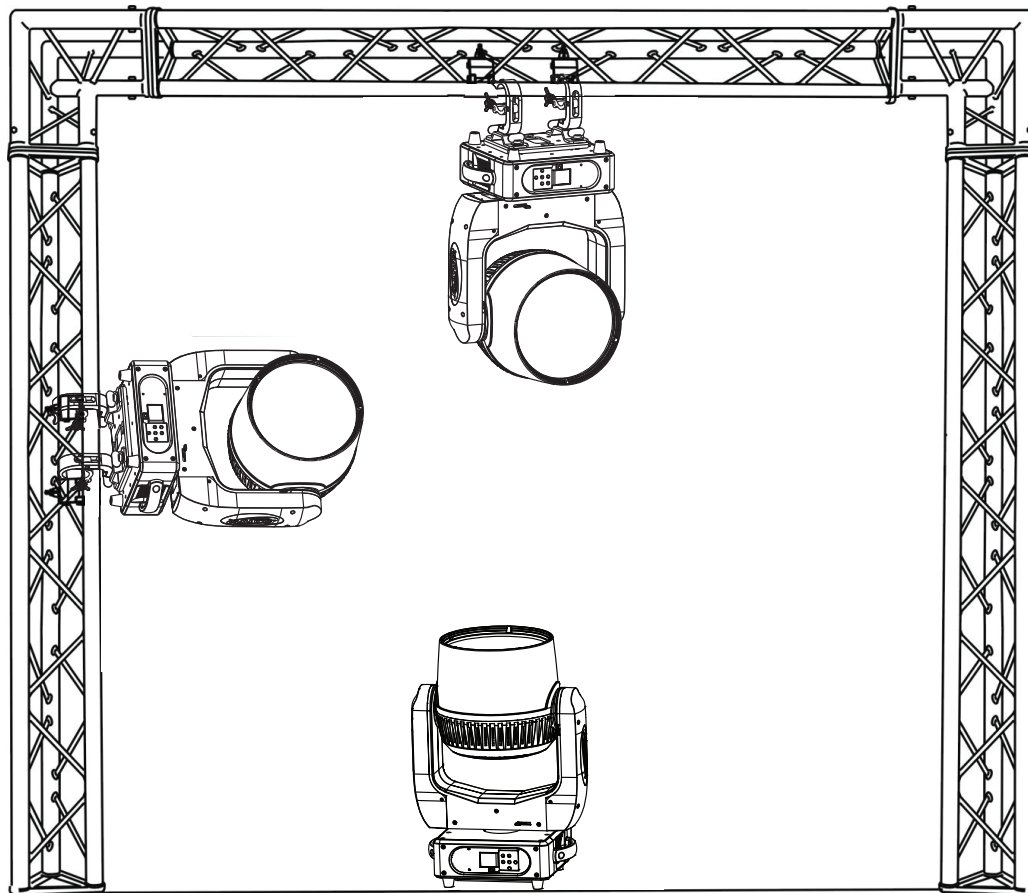

# INSTALLATION INSTRUCTIONS

## POTENTIAL INTERNAL FIXTURE DAMAGE FROM EXTERNAL SOURCES OF LIGHT BEAMS

External sources of light beams from direct sunlight, lighting and moving head fixtures, and lasers, which are focused directly towards the exterior housing and/or penetrate the front lens opening of Elation lighting fixtures, can cause severe internal damage including burning of optics, dichroic color filters, glass and metal gobos, prisms, animation wheels, frost filters, iris, shutters, motors, belts, wiring, discharge lamps, and LEDs.

This issue is not specific only to Elation lighting fixtures, but rather it is a common issue with lighting fixtures from all manufacturers. Although there is no true way to fully prevent this issue from happening, the guidelines below can reduce the risk of potential damage. Contact Elation Service for more details.

**DO NOT EXPOSE THE FIXTURE AND/OR FRONT LENS OPENING TO LIGHT BEAMS FROM DIRECT SUNLIGHT, OTHER LIGHTING OR MOVING HEAD FIXTURES, AND LASERS DURING UNPACKING, INSTALLATION, USE, AND EXTENDED IDLE TIMES OUTDOORS. DO NOT FOCUS A LIGHT BEAM FROM ONE LIGHTING FIXTURE DIRECTLY TOWARDS ANOTHER.**

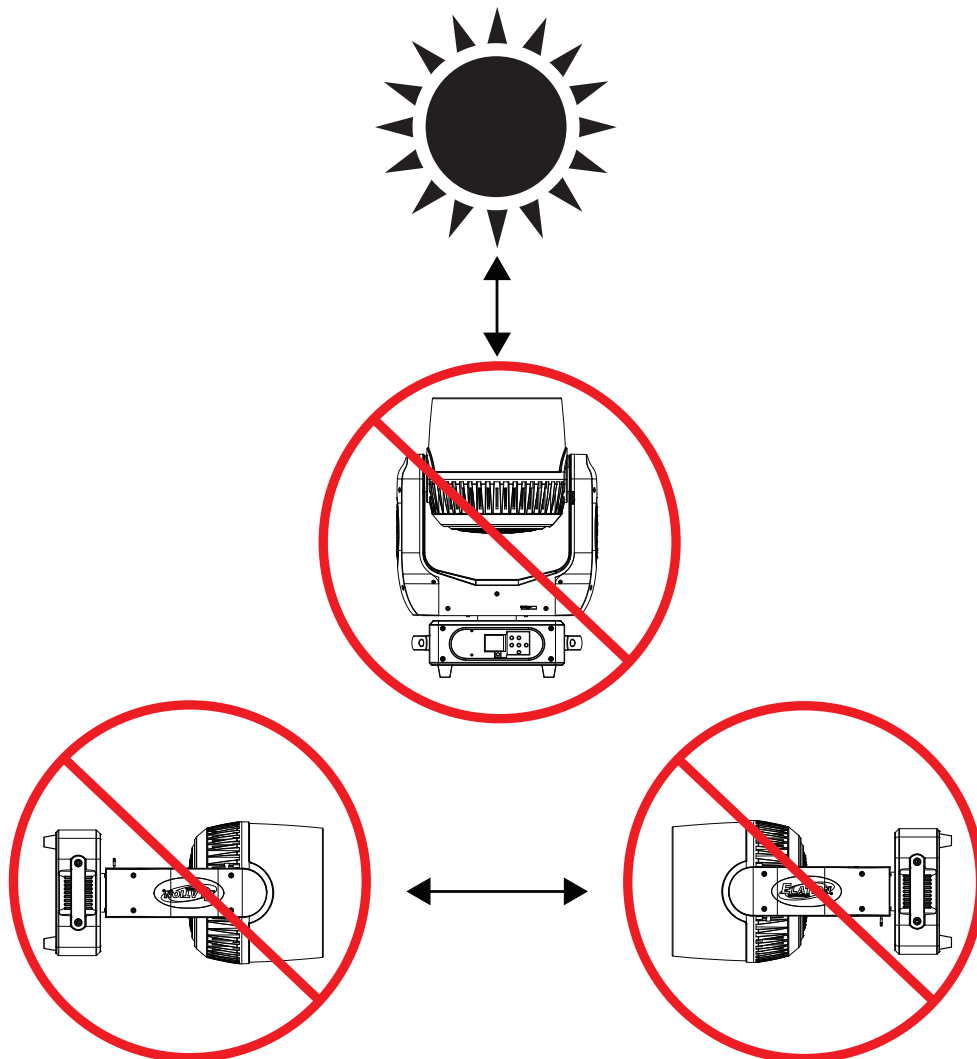

## ACCESSORY INSTALLATION

### SNOOT

1. Place fixture on a flat surface and make sure power is switched off and disconnected.
2. Insert Snoot into fixture head and secure using screws provided. (See image below)

**Do not to over tighten screws, as doing so may damage your fixture.**

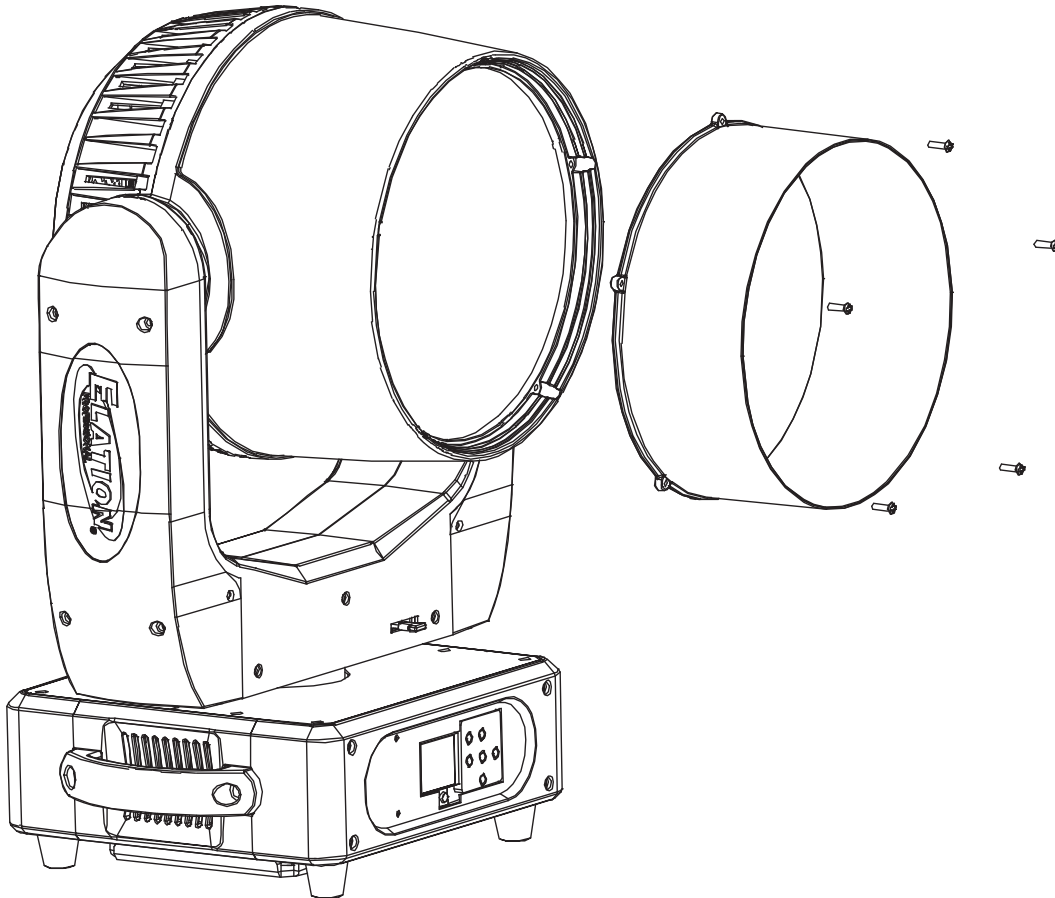

## REMOTE DEVICE MANAGEMENT (RDM)

**NOTE: In order for RDM to work properly, RDM enabled equipment must be used throughout the entire system, including DMX data splitters and wireless systems.**

Remote Device Management (RDM) is a protocol that sits on top of the DMX512 data standard for lighting, allowing the DMX systems of the fixtures to be modified and monitored remotely. This protocol is ideal for instances in which a unit is installed in a location that is not easily accessible.

With RDM, the DMX512 system becomes bi-directional, allowing a compatible RDM enabled controller to send out a signal to devices on the wire, as well as allowing the fixture to respond (known as a GET command). The controller can then use its SET command to modify settings that would typically have to be changed or viewed directly via the unit's display screen, including the DMX Address, DMX Channel Mode, and Temperature Sensors.

### FIXTURE RDM INFORMATION:

| RDM Code | Device ID | Device Model ID | Personality ID   |
|----------|-----------|-----------------|--|
| 0x22A6   | 0000-FFFF | 1863            | 001: 15Ch RGBW<br>002: 16Ch HIS<br>003: 17Ch SRGBI<br>004: 19Ch RGBW |

**Please be aware that not all RDM devices support all RDM features,** and therefore it is important to check beforehand to ensure that the equipment that you are considering includes all of the features that you require.

The following parameters are accessible in RDM on this device:

|                                      |                                      |
|--------------------------------------|--------------------------------------|
| [0x0011] Proxied Device Count        | [0x0404] Lamp Mode                   |
| [0x0200] Sensor Definition           | [0x0405] Device Power Cycles         |
| [0x0201] Sensor Value                | [0x0600] Pan Invert                  |
| [0x0080] Device Model Description    | [0x0601] Tilt Invert                 |
| [0x0081] Manufacturer Label          | [0x0602] Pan Tilt Swap               |
| [0x0082] Device Label                | [0x0500] Display Invert              |
| [0x00E0] DMX Personality             | [0x0122] Default Slot Value          |
| [0x00E1] DMX Personality Description | [0x00B0] Language                    |
| [0x0400] Device Hours                | [0x00A0] Language Capabilities       |
| [0x0015] Comms Status                | [0x00C2] Boot Software Version Label |
| [0x0031] Status ID Description       | [0x00C1] Boot Software Version ID    |
| [0x0032] Clear Status ID             | [0x0070] Product Detail ID List      |
| [0x0401] Lamp Hours                  | [0x0030] Status Messages             |
| [0x0402] Lamp Strikes                | [0x1001] Reset Device                |
| [0x0403] Lamp State                  |                                      |



## SYSTEM MENU

The fixture features with an easy to navigate system menu. The control panel (see image below) located on the front the fixture provides access to the main system menu, where all necessary system adjustments can be made. During normal operation, pressing MODE button once will access the fixture's main menu. Once in the main menu, navigate through the different functions and access the sub-menus with the UP, DOWN, RIGHT, and LEFT buttons. Once you reach a field that requires adjusting, press the ENTER button to activate that field and use the UP and DOWN buttons to adjust the field. Pressing the ENTER button once more will confirm your setting. You may exit the main menu at any time without making any adjustments by pressing the MODE/ESC button.

**NOTE:** To access the LCD Menu Control Display via the internal battery, press and hold the DC SWITCH button for 3 seconds. The LCD Menu Control Display will shut OFF automatically after about 1 minutes of inactivity.

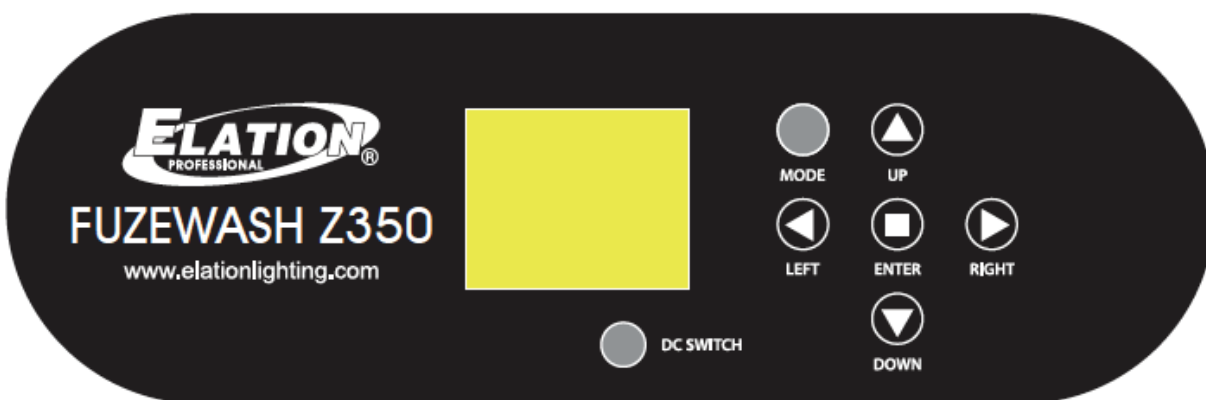

### INFORMATION DISPLAYED DURING INITIAL POWER ON

When the fixture is initially powered ON, the display shows the following information:



### SOFTWARE UPDATES:

Software updates can be uploaded to this unit using the Elation C-Loader II software uploader device. For further information, or to obtain this device, please contact Elation Service: 323-582-3322 | [support@elationlighting.com](mailto:support@elationlighting.com)

# SYSTEM MENU

| ELATION FUZE WASH Z350<br>SYSTEM MENU            |                 |                             |               |  |                                       |
|--|-----------------|-----------------------------|---------------|--|---------------------------------------|
| Supports Software Versions: $\geq$ 1.15   2.2.10 |                 |                             |               |  |                                       |
| Features subject to change without notice.       |                 |                             |               |  |                                       |
| RECEIVE  | Set DMX Address | 001 - XXX                   |               | DMX address setting                                |                                       |
| USER MODE  | User Mode       | <b>15CH RGBW</b>            |               | Set DMX channel / user mode                        |                                       |
|  |                 | 16CH HSI                    |               |  |                                       |
|  |                 | 17CH sRGBI                  |               |  |                                       |
|  |                 | 19CH RGBW                   |               |  |                                       |
|  |                 | User A                      |               |  |                                       |
|  |                 | User B                      |               |  |                                       |
|  |                 | User C                      |               |  |                                       |
|  | Edit A          | Max Chan                    |               | Edit user defined channel assignments              |                                       |
|  | Edit B          | ...                         |               |  |                                       |
|  | Edit C          | Chase Fade                  |               |  |                                       |
| FUNCTION   | Status          | Remote Add                  | On / Off      | Set fixture address via DMX control                |                                       |
|  |                 | NoDMX Mode                  | Hold          | Function if no DMX signal detected                 |                                       |
|  |                 |                             | Auto          |  |                                       |
|  |                 |                             | Blackout      |  |                                       |
|  |                 |                             | Pan Invert    | On / Off   | Pan reverse movement                  |
|  |                 |                             | Tilt Invert   | On / Off   | Tilt reverse movement                 |
|  |                 |                             | Pan Degree    | 630 / <b>540</b>                                   | Pan degree select                     |
|  |                 |                             | Feedback      | On / Off   | Movement feedback                     |
|  |                 |                             | Move Spd      | <b>Speed 1</b> - Speed 4                           | Movement speed select                 |
|  |                 |                             | Stand By      | Off, 01min - 99min                                 | Stand by mode, <b>default = 15min</b> |
|  | Fan Set         | Head Fan                    | Auto          | Fan speed set                                      |                                       |
|  |                 |                             | High          |  |                                       |
|  |                 |                             | Low           |  |                                       |
|  | LCD Set         | Backlight                   | 02min - 60min | LCD backlight shutoff time, <b>default = 05min</b> |                                       |
|  |                 | Flip Display                | On / Off      | Flip LCD display 180 deg                           |                                       |
|  |                 | Key Lock                    | On / Off      | Control front panel buttons key lock               |                                       |
|  |                 | Disp Flash                  | On / Off      | Display flashes when no DMX signal detected        |                                       |
|  | Dim Curve       | <b>Standard</b>             |               | Set dimmer curve mode                              |                                       |
|  |                 | Stage                       |               |  |                                       |
|  |                 | TV                          |               |  |                                       |
|  |                 | Architectur                 |               |  |                                       |
|  | Theatre         |                             |               |  |                                       |
|  | Temp C/F        | Celsius / <b>Fahrenheit</b> |               | Set temperature display units                      |                                       |

CONTINUED ON NEXT PAGE

# SYSTEM MENU

|                         |                  |                                  |                          |  |  |
|-------------------------|------------------|----------------------------------|--------------------------|--|--|
| FUNCTION<br>(continued) | Init Effect      | Pan = xxx                        |                          | Initial effect position  |  |
|                         | Disp Set         | Chan Value                       | Pan...                   | Value of channel   |  |
|                         |                  | Secd Set                         | <b>Sec 1</b>             |  | Set secondary mode preset                |
|                         |                  |                                  | Sec 2                    |  |  |
|                         |                  |                                  | Sec 3                    |  |  |
|                         |                  | Auto Pro                         | <b>Alone</b> / Primary   |  | Set auto program mode                    |
|                         | Dim Curve        | <b>Linear</b>                    |                          |  | Set dimmer curve                         |
| Square                  |                  |                                  |                          |  |  |
| I-Square                |                  |                                  |                          |  |  |
| S-Curve                 |                  |                                  |                          |  |  |
| DFSE                    | On / <b>Off</b>  |                                  | Restore factory settings |  |  |
| INFORMATION             | Time Info        | Current                          | xxxx hours               | Fixture run time from power on   |  |
|                         |                  | Total Time                       | xxxx hours               | Fixture total run time   |  |
|                         |                  | Last Clear                       | xxxx hours               | Clear fixture last run time  |  |
|                         |                  | Timer PIN                        | Passcode = 050           |  | Enter passcode to access clear last menu |
|                         |                  | Clear Last                       | On / <b>Off</b>          |  | Reset fixture last run time              |
|                         | Temp Info        | Head Temp                        | xxx C / <b>xxx F</b>     | Fixture head temperature   |  |
|                         | Error Info       | Error Record 1 - Error Record 10 |                          | Display last 10 error messages   |  |
|                         | Clear Error      | Passcode = 050                   |                          | Clear stored error history   |  |
|                         | Model Info       | Fuze Wash Z350                   |                          | Display model name   |  |
|                         | Software Version | Vx.xx                            |                          | Software versions  |  |
|                         | Gamma            | 1.0                              |                          | Set gamma brightness<br>(only available with software V2.1.8 and higher)           |  |
| 2.0                     |                  |                                  |                          |  |  |
| <b>2.2</b>              |                  |                                  |                          |  |  |
| 2.4                     |                  |                                  |                          |  |  |
| 2.6                     |                  |                                  |                          |  |  |
| 2.8                     |                  |                                  |                          |  |  |
| TEST                    | Reset M          | Pan & Tilt                       |                          | Reset pan/tilt motors  |  |
|                         | Test Chan        |                                  |                          | Test functions   |  |
|                         | Panel Ctrl       |                                  |                          | Fine adjustments   |  |
|                         | Calibrate        | Password = 050                   |                          | Calibration of motors and LEDs<br>(only available with software V2.1.8 and higher) |  |
|                         |                  | Red Low                          |                          |  |  |
|                         |                  | Green Low                        |                          |  |  |
| Blue Low                |                  |                                  |                          |  |  |
|                         | White Low        |                                  |                          |  |  |
| CONTINUED ON NEXT PAGE  |                  |                                  |                          |  |  |

# SYSTEM MENU

|         |            |  |                                     |  |
|---------|------------|--|-------------------------------------|--|
| PROGRAM | Select Pro | Auto Pro Part1 = Program 1-9 (Program 1) |                                     | Select programs to be run              |
|         |            | Auto Pro Part2 = Program 1-9 (Program 2) |                                     |  |
|         |            | Auto Pro Part3 = Program 1-9 (Program 3) |                                     |  |
|         | Edit Pro   | Program 1                                | Program Test                        | Testing program                        |
|         |            | ...                                      | Step 01 = SCxxx                     | Program in loop                        |
|         |            | Program 9                                | Step 64 = SCxxx                     | Save and exit                          |
|         | Edit Sce   | Scene 001<br>-<br>Scene 250              | Pan, Tilt, ...                      | Save and automatically return          |
|         |            |  | -- Fade Time --<br>-- Scene Time -- | Manual scenes edit                     |
|         |            |  | Input by Outside                    | Stores scenes via external DMX console |
|         | Sce Input  | xx - xx                                  |                                     | Automatic scenes recorder              |

# SYSTEM MENU

## Function - Status - Remote Add

When enabled, an external controller can be used to define the DMX address of the fixture.

1. Connect the fixture to the external controller and power both devices on.
2. Set the DMX value of Channel 1 on the controller to (7).
3. Set the DMX value of Channel 2 on the controller to (7) or (8), depending on the desired DMX address.
  - When set to (7), the DMX address can be set between (1) and (255).
  - When set to (8), the DMX address can be set between (256) and (511).
4. Using Channel 3 on the controller, set the desired DMX address of the fixture.
  - Example 1: If the desired DMX address is 57, set Channel 1 to a value of (7), set Channel 2 to a value of (7), and then set Channel 3 to a value of (57).
  - Example 2: If the desired DMX address is 420, set Channel 1 to a value of (7), set Channel 2 to a value of (8), and then set Channel 3 to a value of (164). (256+164=420)
5. After setting Channel 3 to the desired DMX address value, wait for approximately 20 seconds for the fixture to complete the address reset function.

## Function - Dim Mode

Select desired DIMMER MODE (Standard, Stage, TV, Architectural, Theatre).

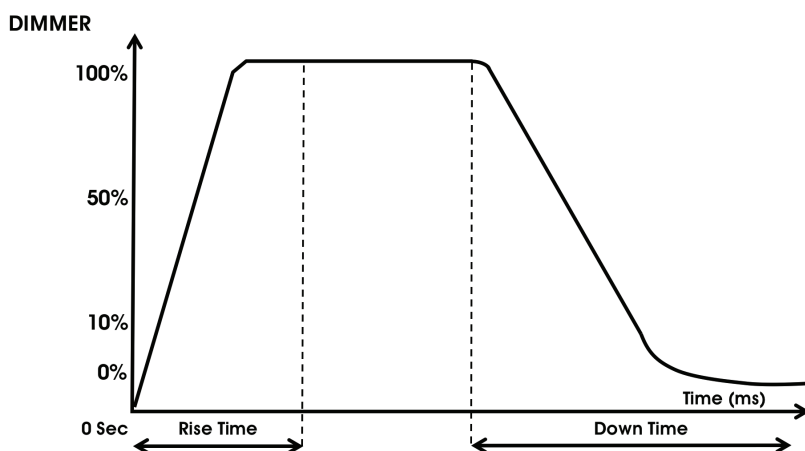

| Dimming Curve Ramp Effect | 0 sec Fade Time |                | 1 sec Fade Time |                |
|---------------------------|-----------------|----------------|-----------------|----------------|
|                           | Rise Time (ms)  | Down Time (ms) | Rise Time (ms)  | Down Time (ms) |
| Standard (default)        | 0               | 0              | 0               | 0              |
| Stage                     | 780             | 1100           | 1540            | 1660           |
| TV                        | 1180            | 1520           | 1860            | 1940           |
| Architectural             | 1380            | 1730           | 2040            | 2120           |
| Theatre                   | 1580            | 1940           | 2230            | 2280           |

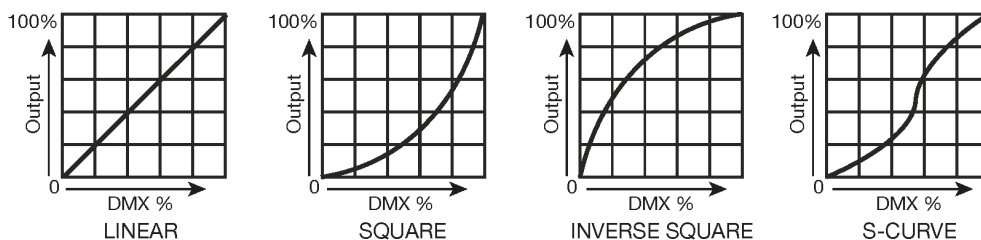

## SYSTEM MENU

### Test – Calibrate

#### **ONLY QUALIFIED TECHNICIANS SHOULD PERFORM THIS FUNCTION**

This function allows small adjustments to be made to the effect wheels to compensate for wear, or in the event a sensor has been knocked slightly out of place. Due to the fact that improper use of this function can result in undesired operation, this function has been password protected. The password is **050** and must be entered each time the calibration menu function is accessed. Because calibration is an extremely delicate procedure that should be performed only by skilled, qualified personnel, instructions for this procedure are left out of this manual. For a first time calibrator, please contact our customer support team for step-by-step instructions.

## FAN CONTROL

The Fuze Wash Z350 is a high-performance fixture suited for multiple applications. For noise critical environments such as Theater, Opera, or Orchestral Halls, it offers various fan operation modes which remove unwanted noise distractions for the audience and performers. Fan Modes can be changed remotely via the DMX control channel, allowing the fixture to offer high output or whisper-silent operation at a moment's notice. All Fan Modes smoothly transition over a brief period, preventing unwanted attraction to the fixture.

**Auto (Default)** – Fans only run at the speeds needed to keep the LED engine within a safe temperature range, and ensures optimal performance of the fixture. They will turn off if possible; for example, when the fixture is dimmed to a low intensity. Fans sense the ambient and fixture temperature and will, at all times, try to keep noise levels at a minimum. The fixture output will only be reduced when the LED engine cannot be cooled to its safe operating range due to a high ambient temperature.

**NOTE: This mode is recommended for daily operation.**

**High** – Fan speeds are increased throughout the fixture for the most efficient cooling. This mode will increase wear on the fans and should only be utilized in exceptional circumstances. Fans will always run, even if the fixture is dimmed. Fixture output is kept at 100% unless the LED engine temperature reaches an unsafe temperature, at which point the fixture will reduce power carefully to ensure continued safe operation. This mode is only required in very high ambient temperatures when automatic fan speed adjustments are not desired.

**Low** – Fan speeds are reduced throughout the fixture for a lower noise profile. The fixture output is also reduced to approximately 80%. This mode should be sufficient for most uses where lower noise is required.

# DMX TRAITS

| ELATION FUZE WASH Z350<br>DMX CHANNEL TRAITS   |                 |            |            |               |                                    |
|--|-----------------|------------|------------|---------------|------------------------------------|
| Supports Software Versions: 2.1.10   |                 |            |            |               |                                    |
| Features subject to change without notice.<br>Rotation direction (clockwise/counter-clockwise) and control of effects depends on head orientation and pan/tilt settings. |                 |            |            |               |                                    |
| CHANNEL  |                 |            |            | DMX<br>VALUES | FUNCTION                           |
| 15<br>RGBW   | 16<br>HSI       | 17<br>RGBI | 19<br>RGBW |               |                                    |
| 1  | 1               | 1          | 1          | 000 - 255     | <b>Pan Movement</b>                |
| 2  | 2               | 2          | 2          | 000 - 255     | <b>Pan Movement Fine</b>           |
| 3  | 3               | 3          | 3          | 000 - 255     | <b>Tilt Movement</b>               |
| 4  | 4               | 4          | 4          | 000 - 255     | <b>Tilt Movement Fine</b>          |
| 5  |                 | 6          | 5          | 000 - 255     | <b>Red, 0% to 100%</b>             |
| 6  |                 | 7          | 6          | 000 - 255     | <b>Green, 0% to 100%</b>           |
| 7  |                 | 8          | 7          | 000 - 255     | <b>Blue, 0% to 100%</b>            |
| 8  |                 |            | 8          | 000 - 255     | <b>White, 0% to 100%</b>           |
| 9  | 5               | 5          | 10         |               | <b>Shutter/Strobe</b>              |
|  |                 |            |            | 000 - 031     | LED Off                            |
|  |                 |            |            | 032 - 063     | LED On                             |
|  |                 |            |            | 064 - 095     | Strobe Effect, slow to fast        |
|  |                 |            |            | 096 - 127     | LED On                             |
|  |                 |            |            | 128 - 159     | Pulse Effect in Sequences          |
|  |                 |            |            | 160 - 223     | Random Strobe Effect, slow to fast |
| 224 - 255  | LED On          |            |            |               |                                    |
|  | 6               |            |            | 000 - 255     | <b>Hue, 0% to 100%</b>             |
|  | 7               |            |            | 000 - 255     | <b>Saturation, 0% to 100%</b>      |
|  | 8               | 9          |            | 000 - 255     | <b>Intensity, 0% to 100%</b>       |
| 9  | 10              | 10         | 9          |               | <b>Color Presets</b>               |
|  |                 |            |            | 000           | Off                                |
|  |                 |            |            | 001 - 004     | Color Preset 01                    |
|  |                 |            |            | 005 - 008     | Color Preset 02                    |
|  |                 |            |            | 009 - 012     | Color Preset 03                    |
|  |                 |            |            | 013 - 016     | Color Preset 04                    |
|  |                 |            |            | 017 - 020     | Color Preset 05                    |
|  |                 |            |            | 021 - 024     | Color Preset 06                    |
|  |                 |            |            | 025 - 028     | Color Preset 07                    |
|  |                 |            |            | 029 - 032     | Color Preset 08                    |
|  |                 |            |            | 033 - 036     | Color Preset 09                    |
|  |                 |            |            | 037 - 040     | Color Preset 10                    |
|  |                 |            |            | 041 - 044     | Color Preset 11                    |
|  |                 |            |            | 045 - 048     | Color Preset 12                    |
|  |                 |            |            | 049 - 052     | Color Preset 13                    |
|  |                 |            |            | 053 - 056     | Color Preset 14                    |
|  |                 |            |            | 057 - 060     | Color Preset 15                    |
| 061 - 064  | Color Preset 16 |            |            |               |                                    |
| 065 - 068  | Color Preset 17 |            |            |               |                                    |

CONTINUED ON NEXT PAGE



# DMX TRAITS

| CHANNEL    |                 |            |            | DMX VALUES | FUNCTION                         |
|------------|-----------------|------------|------------|------------|----------------------------------|
| 15<br>RGBW | 16<br>HSI       | 17<br>RGBI | 19<br>RGBW |            |                                  |
|            | 9               | 10         | 9          |            | <b>Color Presets (continued)</b> |
|            |                 |            |            | 069 - 072  | Color Preset 18                  |
|            |                 |            |            | 073 - 076  | Color Preset 19                  |
|            |                 |            |            | 077 - 080  | Color Preset 20                  |
|            |                 |            |            | 081 - 084  | Color Preset 21                  |
|            |                 |            |            | 085 - 088  | Color Preset 22                  |
|            |                 |            |            | 089 - 092  | Color Preset 23                  |
|            |                 |            |            | 093 - 096  | Color Preset 24                  |
|            |                 |            |            | 097 - 100  | Color Preset 25                  |
|            |                 |            |            | 101 - 104  | Color Preset 26                  |
|            |                 |            |            | 105 - 108  | Color Preset 27                  |
|            |                 |            |            | 109 - 112  | Color Preset 28                  |
|            |                 |            |            | 113 - 116  | Color Preset 29                  |
|            |                 |            |            | 117 - 120  | Color Preset 30                  |
|            |                 |            |            | 121 - 124  | Color Preset 31                  |
|            |                 |            |            | 125 - 128  | Color Preset 32                  |
|            |                 |            |            | 129 - 132  | Color Preset 33                  |
|            |                 |            |            | 133 - 136  | Color Preset 34                  |
|            |                 |            |            | 137 - 140  | Color Preset 35                  |
|            |                 |            |            | 141 - 144  | Color Preset 36                  |
|            |                 |            |            | 145 - 148  | Color Preset 37                  |
|            |                 |            |            | 149 - 152  | Color Preset 38                  |
|            |                 |            |            | 153 - 156  | Color Preset 39                  |
|            |                 |            |            | 157 - 160  | Color Preset 40                  |
|            |                 |            |            | 161 - 164  | Color Preset 41                  |
|            |                 |            |            | 165 - 168  | Color Preset 42                  |
|            |                 |            |            | 169 - 172  | Color Preset 43                  |
|            |                 |            |            | 173 - 176  | Color Preset 44                  |
|            |                 |            |            | 177 - 180  | Color Preset 45                  |
|            |                 |            |            | 181 - 184  | Color Preset 46                  |
|            |                 |            |            | 185 - 188  | Color Preset 47                  |
|            |                 |            |            | 189 - 192  | Color Preset 48                  |
| 193 - 196  | Color Preset 49 |            |            |            |                                  |
| 197 - 200  | Color Preset 50 |            |            |            |                                  |
| 201 - 204  | Color Preset 51 |            |            |            |                                  |
| 205 - 208  | Color Preset 52 |            |            |            |                                  |
| 209 - 212  | Color Preset 53 |            |            |            |                                  |
| 213 - 216  | Color Preset 54 |            |            |            |                                  |
| 217 - 220  | Color Preset 55 |            |            |            |                                  |
| 221 - 224  | Color Preset 56 |            |            |            |                                  |
| 225 - 228  | Color Preset 57 |            |            |            |                                  |
| 229 - 232  | Color Preset 58 |            |            |            |                                  |

CONTINUED ON NEXT PAGE

# DMX TRAITS

| CHANNEL    |           |            |            | DMX VALUES | FUNCTION   |
|------------|-----------|------------|------------|------------|--|
| 15<br>RGBW | 16<br>HSI | 17<br>RGBI | 19<br>RGBW |            |  |
|            |           |            |            |            | <b>Color Presets (continued)</b>                 |
|            |           |            |            | 233 - 236  | Color Preset 59                                  |
|            |           |            |            | 237 - 240  | Color Preset 60                                  |
|            | 9         | 10         | 9          | 241 - 244  | Color Preset 61                                  |
|            |           |            |            | 245 - 248  | Color Preset 62                                  |
|            |           |            |            | 249 - 252  | Color Preset 63                                  |
|            |           |            |            | 253 - 255  | Color Preset 64                                  |
| 10         |           |            | 11         | 000 - 255  | <b>Dimmer Intensity, 0% to 100%</b>              |
| 11         |           |            | 12         | 000 - 255  | <b>Dimmer Intensity Fine</b>                     |
| 12         | 10        | 11         | 13         | 000 - 255  | <b>Zoom, 0% (6 degrees) to 100% (46 degrees)</b> |
|            |           |            |            |            | <b>Program Macros</b>                            |
|            |           |            |            | 000        | No Function                                      |
|            |           |            |            | 001 - 020  | Color Macro 01                                   |
|            |           |            |            | 021 - 040  | Color Macro 02                                   |
|            |           |            |            | 041 - 060  | Color Macro 03                                   |
|            |           |            |            | 061 - 080  | Color Macro 04                                   |
|            |           |            |            | 081 - 100  | Color Macro 05                                   |
|            |           |            |            | 101 - 120  | Color Macro 06                                   |
|            |           |            |            | 121 - 140  | Color Macro 07                                   |
|            |           |            |            | 141 - 160  | Color Macro 08                                   |
|            |           |            |            | 161 - 180  | Color Macro 09                                   |
|            |           |            |            | 181 - 200  | Color Macro 10                                   |
|            |           |            |            | 201 - 230  | Color Macro 11                                   |
|            |           |            |            | 231 - 240  | Color Macro 12                                   |
|            |           |            |            | 241 - 250  | Color Macro 13                                   |
|            |           |            |            | 251 - 255  | Gradient Color Macro                             |
|            |           |            |            |            | <b>Program Macro Speed</b>                       |
|            |           |            |            | 000 - 125  | Counter-Clockwise Movement, fast to slow         |
|            |           |            |            | 126 - 130  | Stop Movement                                    |
|            |           |            |            | 131 - 255  | Clockwise Movement, slow to fast                 |
|            | 12        | 13         | 15         |            |  |
|            | 13        | 14         | 16         | 000 - 255  | <b>Program Macro Fade, 0% to 100%</b>            |
|            |           |            |            |            | <b>Dimming Curve Modes</b>                       |
|            |           |            |            | 000 - 020  | Standard   |
|            |           |            |            | 021 - 040  | Stage  |
|            |           |            |            | 041 - 060  | TV   |
|            |           |            |            | 061 - 080  | Architectural                                    |
|            |           |            |            | 081 - 100  | Theatre  |
|            |           |            |            | 101 - 255  | Default to unit setting                          |
|            |           |            |            |            | <b>Pan/Tilt Movement Speed</b>                   |
|            |           |            |            | 000 - 225  | Speed, maximum to minimum                        |
|            |           |            |            | 226 - 235  | Blackout by movement                             |
|            |           |            |            | 236 - 255  | No Function                                      |
| 13         | 14        | 15         | 17         |            |  |
| 14         | 15        | 16         | 18         |            |  |

CONTINUED ON NEXT PAGE

# DMX TRAITS

| CHANNEL    |           |            |            | DMX VALUES | FUNCTION   |
|------------|-----------|------------|------------|------------|--|
| 15<br>RGBW | 16<br>HSI | 17<br>RGBI | 19<br>RGBW |            |  |
| 15         | 16        | 17         | 19         |            | <b>Lamp On/Off, Reset, and Internal Programs</b> |
|            |           |            |            | 000 - 079  | Normal   |
|            |           |            |            | 080 - 084  | All Motor Reset                                  |
|            |           |            |            | 085 - 099  | No Function                                      |
|            |           |            |            | 100 - 119  | Internal Program 1 (scene 1-8)                   |
|            |           |            |            | 120 - 139  | Internal Program 2 (scene 9-16)                  |
|            |           |            |            | 140 - 159  | Internal Program 3 (scene 17-24)                 |
|            |           |            |            | 160 - 179  | Internal Program 4 (scene 25-32)                 |
|            |           |            |            | 180 - 199  | Internal Program 5 (scene 33-40)                 |
|            |           |            |            | 200 - 219  | Internal Program 6 (scene 41-48)                 |
|            |           |            |            | 220 - 239  | Internal Program 7 (scene 49-56)                 |
|            |           |            |            | 240 - 255  | No Function                                      |

## ERROR CODES

When power is applied, the unit will automatically enter a “Motor Reset” mode, which brings all the internal motors to the home position. If there is an internal problem with one or more of the motors, an error code (see below) will flash on the control display.

| ERROR CODE | DESCRIPTION   |
|------------|---|
| TILT Er    | The TILT movement is not located in the default position after the reset. This message will appear after a fixture reset if the magnetic-indexing circuit malfunctions (sensor failed or magnet is missing) or there is a motor failure (defective motor or defective motor IC drive on main PCB). This error may also occur if the head was blocked during a reset function            |
| PAN Er     | The PAN movement is not located in the default position after the reset. This message will appear after a fixture reset if the magnetic-indexing circuit malfunctions (sensor failed or magnet is missing) or there is a motor failure (defective motor or a defective motor IC drive on the main PCB). This error may also occur if the head/yoke was blocked during a reset function. |

# SPECIFICATIONS

## SOURCE

350W RGBW COB LED

100,000 Hour Average LED Life\*

\*May vary depending on several factors including but not limited to: Environmental Conditions, Power/Voltage, Usage Patterns (On-Off Cycling), Control, and Dimming.

## PHOTOMETRIC DATA

60,280 LUX 5,600 FC @6.6' (2m) (6° Full ON)

3,735 LUX 347 FC @6.6' (2m) (46° Full ON)

## COLOR

RGBW

## EFFECTS

RGBW Color Mixing

6° to 46° Beam Zoom Range

Electronic Strobe, Dimming and Variable Dimming Curves

64 Color Presets and 14 Unique Color Macros

Pan Angle: 540°/630°

Tilt Angle: 250°

## CONTROL / CONNECTIONS

4 DMX Channel Modes (19 Total Channels)

7 Button Control Panel and LCD Menu Display

RDM (Remote Device Management)

3pin/5pin DMX and Locking Power Cable In/Out

With Wired Digital Communication Network

## SIZE / WEIGHT

Length: 16.3" (414mm)

Width: 11.6" (294mm)

Vertical Height: 22.7" (578mm)

Weight: 45 lbs. (20.4 kg)

## ELECTRICAL / THERMAL

AC 110-240V - 50/60Hz

399W Max Power Consumption

Multiple Unit Power Linking

5°F to 113°F (-15°C to 45°C)

BTU/hr (+/- 10%) 1360.59

## APPROVALS / RATINGS

CE | cETLus | IP30



Please note: Specifications and improvements in the design of this unit and this manual are subject to change without notice.

# DIMENSIONAL DRAWINGS

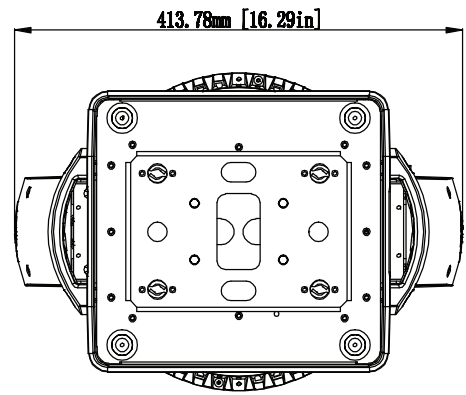
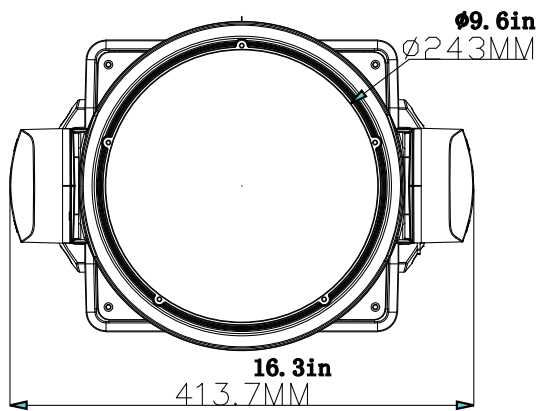
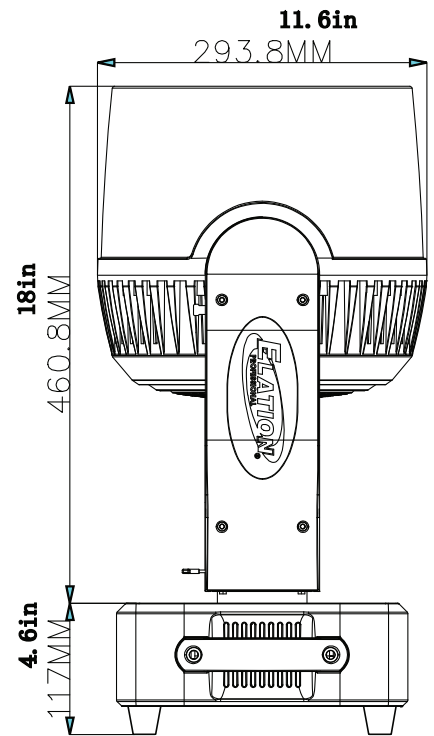
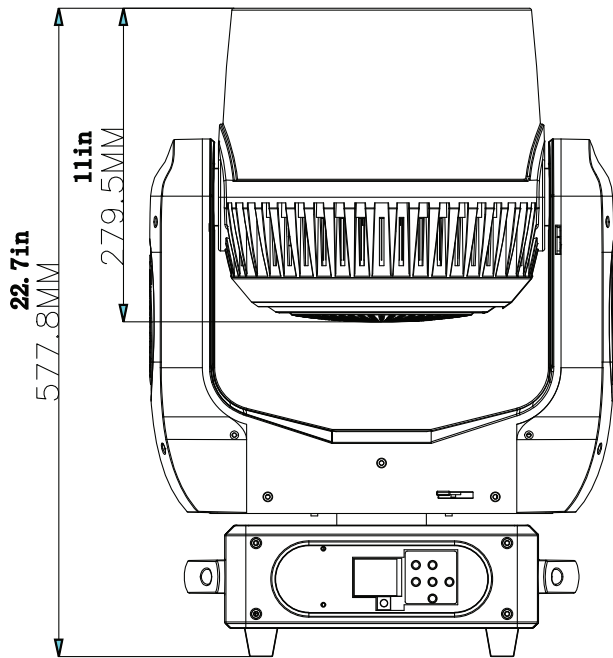

# DIMENSIONAL DRAWINGS

## OPTIONAL SNOOT INSTALLED

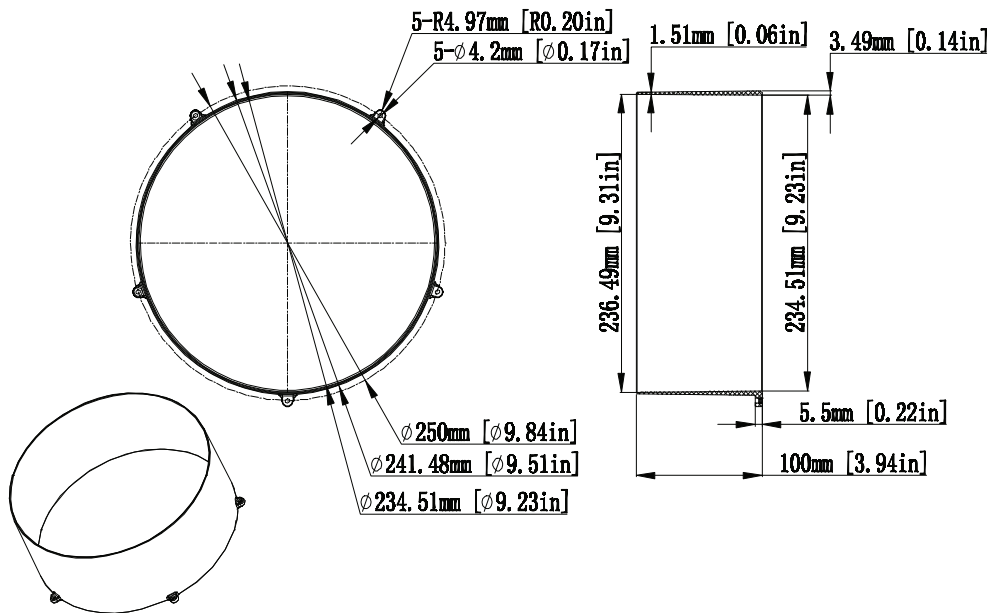
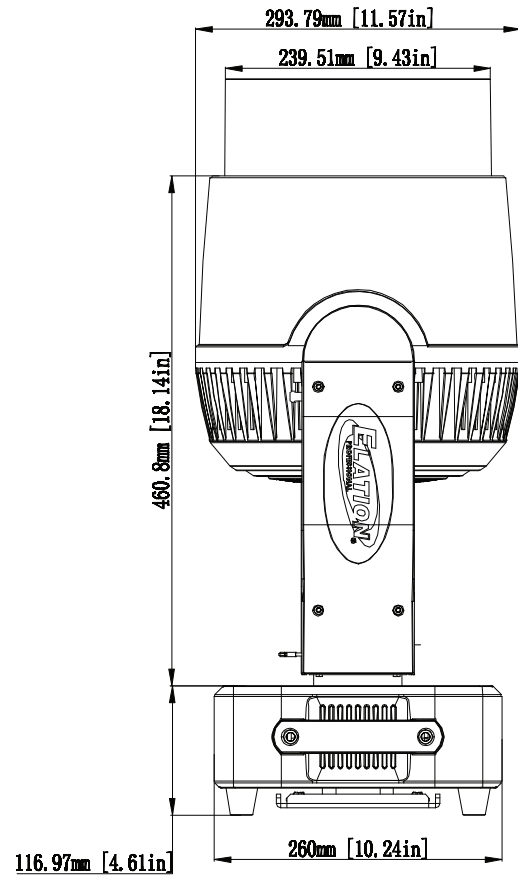
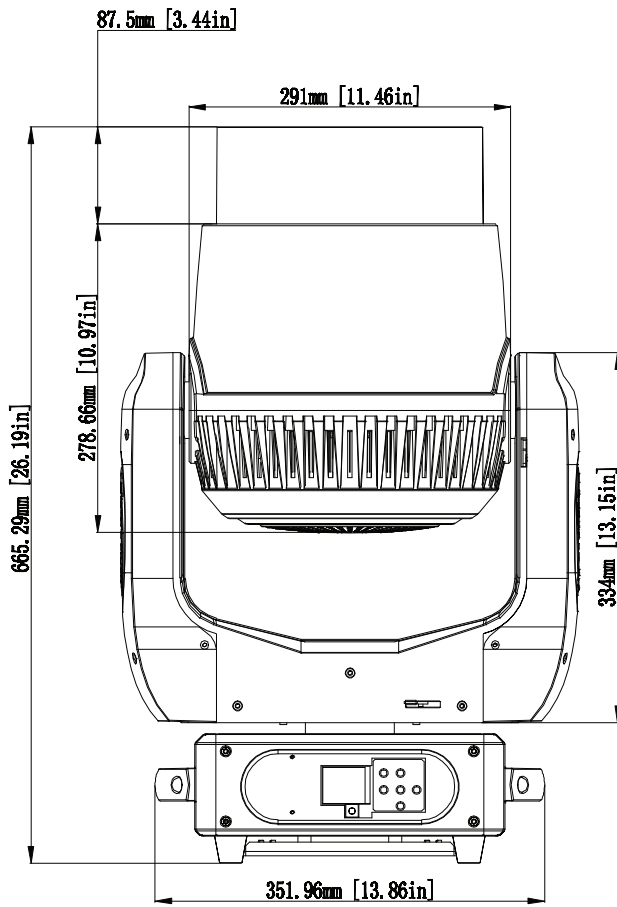

## OPTIONAL ACCESSORIES

| ORDER CODE    | ITEM                                    |
|---------------|---|
| FW350SNOOT    | Fuze Wash Z350 Snoot                    |
| TRIGGER CLAMP | Heavy Duty Wrap Around Hook Style Clamp |
| DRC350FUZE    | Fuze Wash Z350 Quad Road Case           |
| AC3PDMX5PRO   | 5 ft (1.5m) 3pin DMX Cable*             |
| AC5PDMX5PRO   | 5 ft (1.5m) 5pin DMX Cable*             |
| PLC3          | 3 ft (1m) Link Cable*                   |

\*additional cable lengths available

## FCC STATEMENT

This device complies with Part 15 of the FCC Rules. Operation is subject to the following two conditions: (1) this device may not cause harmful interference, and (2) this device must accept any interference received, including interference that may cause undesired operation.

## FCC RADIO FREQUENCY INTERFERENCE WARNINGS & INSTRUCTIONS

This product has been tested and found to comply with the limits as per Part 15 of the FCC Rules. These limits are designed to provide reasonable protection against harmful interference in a residential installation. This device uses and can radiate radio frequency energy and, if not installed and used in accordance with the included instructions, may cause harmful interference to radio communications. However, there is no guarantee that interference will not occur in a particular installation. If this device does cause harmful interference to radio or television reception, which can be determined by turning the device off and on, the user is encouraged to try to correct the interference by one or more of the following methods:

- Reorient or relocate the device.
- Increase the separation between the device and the receiver.
- Connect the device and the radio receiver to electrical outlets on a different circuits.
- Consult the dealer or an experienced radio/TV technician for help.



Europe Energy Saving Notice

Energy Saving Matters (EuP 2009/125/EC)

Saving electric energy is a key to help protecting the environment. Please turn off all electrical products when they are not in use. To avoid power consumption in idle mode, disconnect all electrical equipment from power when not in use. Thank you!





